

TBQSe

Quantometer



TBQSe Quantometer with electronic index

Applications

The TBQSe Quantometer is a turbine meter for operational natural gas - volume measurement and for other non-aggressive gases such as propane, butane, air, carbon dioxide (CO₂) or inert gases used in internal and controlling processes of various types, especially in industrial thermal processing facilities.

Key features

- Meter size G 10 to G 1000
- Flow rates from 16 to 1600 m³/h
- Nominal sizes from DN 2S (1 ") to DN 150 (6")
- Pressure class PN 16 and ANSI 150
- Measuring range from 1:10 to 1:20
- Meter body made of anodized high strength aluminum
- Maintenance free based on permanent lubrication of the ball bearings
- Manual lubrication of the ball bearings by means of oil pump as option
- Electronic index head standard made of Aluminum
- Lithium battery with a calculated life time under standard conditions of 5 years, optional external power supply
- Integral electronic volume corrector (AGA NX-19) and fixed value as option
- Connection of an external pressure and temperature measurement is possible
- Communication options: serial RS 485 interface, Mod bus, M-Bus, 4 to 20mA analog output, high frequency or low frequency pulse output, pressure and temperature inputs
- Rotating index head (180°)
- Parameterization via a PC based software (HMI)
- Recommended straight inlet pipe $\geq 3DN$ and outlet pipe $\geq 2DN$
- Horizontal and vertical mounting position
- Approval according to PED (PED 2014/68/EU)
- ATEX / IECEx Ex-Zone 0; Ex ia IIC T4 Ga

Description and operation

The TBQSe Quantometer is a turbine gas meter that registers the operating volume using a nine-digit electronic index. The flow of the gas to be measured causes the turbine rotor to rotate. The gas flow is narrowed on an annular cross section, is accelerated and directed onto the smooth-running Aluminum rotor. The number of rotations is proportional to the measured gas volume; the frequency of rotations is proportional to the actual gas flow.

The rotation of the rotor is transmitted via a magneto-resistance sensor from the gas pressurized area to the electronic index which is in the atmospheric environment. The CPU is receiving the high frequency signal for the magneto-resistance sensor to calculate the gas flow and gas volume under operating conditions. If the optional electronic volume corrector function is installed the gas flow and gas volume under standard conditions will be calculated according AGA NX-19. The calculation can be based on fixed factors for temperature and pressure or on optionally installed temperature and pressure sensors. The TBQSe is designed to have one external temperature and one external pressure transmitter installed directly in the meter.

The TBQSe has several options to transmit the measured and calculated data to a digital control system (DCS). The TBQSe is by standard equipped with alternatively RS 485 or M-Bus or modbus interface and one high frequency (HF) as well as one low frequency (LF) pulser. If an external power supply is connected to the TBQSe one 4 to 20mA - configurable signal is available. The rotation of the rotor can be scanned additionally with one external high frequency

(HF) sensor as an option. The HF-sensor signal allows the determination of the actual gas flow in high-resolution and can be transmit to any digital control system (DCS) for flow control purposes.

The electronic index of the TBQSe is equipped with a 512kB non-volatile EEPROM to save 1500 records and all parameters. Parameterization is possible with a PC based software supplied with the device and through the serial communication interface of the TBQSe.

Technical specifications	
Gas temperature:	-20 °C to +60 °C
Ambient temperature:	-20 °C to +60 °C
Storage temperature:	-30 °C to +60 °C
Operating pressure:	16 bar (g)
Protection class:	IP 65
Materials	
Meter housing:	Aluminum alloy
Turbine rotor:	Aluminum alloy
Meter index head:	Aluminum alloy
PED-Approval:	HPiVS/P1001-103-Q-06
Reproducibility:	<0,2%
Overload:	Short term up to 1.25 Q _{max}
Pressure change rate:	< 350 mbar/s
Electronic index:	
Power supply:	Lithium battery with a calculated life time under standard conditions of 5 years, alternatively external power supply as option
Display:	LCD Display for flow and volume under operating and standard conditions, pressure and temperature as well as the status of the battery
Keys:	4 keys
Counter:	Nine-digit electronic index
Memory:	Non-volatile 512 kB EPROM for saving the parameters and set of 1500 records
Electronic volume correction	
(option):	AGA NX 19 or fixed factors
Standard conditions:	selectable, standard configuration is 273, 15°K (0°C); 1013,25 mbar
Parameterization:	PC based software (HMI)
Communication:	
Pulse output:	1 LF-pulser or 1 HF-pulser; Option: additionally 1 HF-pulser (at the turbine wheel)
Analog output (option):	14 to 20mA output (only with external power supply)
Serial communication:	1 RS 485 or M-Bus interface
Protocol:	Modbus RTU, M-Bus
Connections:	
Pressure:	1 connection with 1/4" NPT –thread
Temperature:	1 thermowell with G 1/4" -thread (option)

Error limits

Maximum permissible error limits: G16:±2.0%FS; G25-G1000:±1.0%(20%Q_{max}≤Q≤Q_{max}); ±2.0(Q_{min}≤Q<20%Q_{max});

The Quantometers TBQSe are all initially calibrated within the specified measurement errors. Reduced measurement errors limits are optionally available. The Quantometers TBQSe are manufactured with large measurement ranges due to the precision machining of the parts and a reproducible assembly process.

TBQSe Quantometer

Performance data

DN [mm/inch]	G-Type	Qmin [m3/h]	Qmax [m3/h]	HF* [imp/m3]	NF [imp/m3]	Pressure loss [mbar] at Qmax and $\rho=1$ bar abs.		Error limit
						Air ($\rho=1.2$ kg/m3)	Natural gas ($\rho=0.83$ kg/m3)	
25/1"	10	2	16	140000	10	23	15	±2% FS
25/1"	16	2.5	25	140000	10	10	5	±2% FS
25/1"	25	4	40	140000	10	25	15	
40/1 1/2"	25	4	40	140000	10	10	5	
40/1 1/2"	40	6.5	65	140000	10	25	15	
50/2" a	40	5/6.5	65	104000	10	8	3	
50/2" a	65	10	100	104000	10	20	7	
50/2" b	40	5/6.5	65	104000	10	8	3	
50/2" b	65	10	100	104000	10	20	7	±1.5%(20%Q _{max}
80/3"	100	8	160	27000	1	6	3	≤Q≤Q _{max}
80/3"	160	12.5	250	27000	1	15	6	±3(Q _{min} ≤Q
80/3"	250	20	400	27000	1	25	16	<20%Q _{max})
100/4"	160	12.5	250	13500	1	5	1	
100/4"	250	20	400	13500	1	12	3	
100/4"	400	32	650	13500	1	25	9	
150/6"	400	32	650	5400	1	6	9	
150/6"	650	50	1000	5400	1	16	6	
150/6"	1000	80	1600	5400	1	25	16	

* The absolute number of the pulses depends on the meter size and the single meter itself. The stated values are of typical size. Exact values are determined during each calibration of the meter and are stated on the nameplate.

The Quantometer TBQSe show very stable and reproducible measurement results. The measurement cartridge has been designed to be assembled into the pressure containing housing positioned by soft O-rings. This makes the TBQSe meter very robust against any torsional and bending stresses resulting out of installation conditions. The meters can withstand far more than double the specified torsional and bending stresses implied through the installation as defined for example in EN 12261.

The lifetime durability of the Quantometer TBQSe is very stable due to the large dimensioned high precision ball bearings "made in Germany" along with the high precision machining of the body and all moving parts. All TBQSe Quantometers are equipped with machined aluminum turbine wheels. After machining all aluminum parts, especially the turbine wheel, are hard anodized for less friction and higher resistance to mechanical wear and tear or chemical influences.

In case of contaminations or dust in the measured gas it is recommended to install an optional oil lubrication pump and a filter in the pipe for longer meter lifetime.

Meter design

The pressure containing housing (1) is very robust against torsional or bending forces due to the large cross sections. The aluminum turbine wheel (2) is machined out of full material on a 4 axis machine, dynamically precision balanced, and hard anodized. The computer optimized profile of the helical turbine blades in combination with the fluid dynamic optimized inlet flow straightener (5) provide for a very stable measurement characteristic also under elevated operating pressure conditions.

The high precision ball bearings "made in Germany" ensure minimal friction under all operating conditions. The complete measuring cartridge (6) is positioned in the housing by O-rings. This design feature also creates a circular room with absolute static operating pressure for very precise pressure measurement without any dynamic flow influences. The turning of the turbine wheel is transmitted via a pressure stable and leak tight magnetoresistance sensor (4) to the nine-digit electronic counter (3) with an environmental protection class of IP 65. The Quantometer TBQ5e can be installed horizontally and vertically up or down due to the 180° turnable index head.

The optional oil lubrication of the ball bearings is ensured through the lubrication pump. The complete design of the TBQ5e Quantometer has been aimed to be very robust in combination with highest measurement performance. The electronic index of the TBQ5e can optionally be equipped with an electronic volume corrector. In this case the gas flow and gas volume under standard conditions will be calculated according AGA NX-19. For this calculation an external pressure and temperature transmitter has to be installed to the TBQ5e. The TBQ5e is designed to have one external temperature and one external pressure transmitter installed to the meter. If there is no external pressure and temperature sensor is installed fixed values for the calculations due to AGA NX-19 will be used.

The TBQ5e has several options to transmit the measured and calculated data to a digital control system (DC5). The TBQ5e is by standard equipped with RS 485 or M-Bus interface and one high frequency (HF) or one low frequency (LF) pulser. If an external power supply is connected to the TBQ5e one 4 to 20mA - signal is available. The rotation of the rotor can be scanned additionally with one frequency (HF) sensor as an option. The HF-sensor signal allows the determination of the actual gas flow in high-resolution and can be transmit to any digital control system (DC5) for flow control purposes.

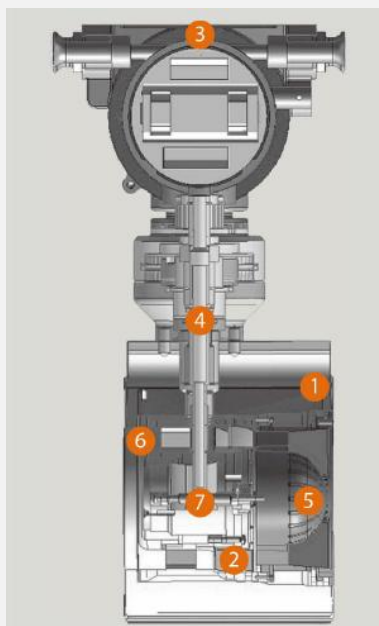

1. Pressure containing housing
2. Turbine wheel
3. Mechanical counter I index
4. Magnetic coupling
5. Inlet flow straightener
6. Measuring cartridge
7. Gear train

TBQSe Quantometer

Dimensions and weights

DN [mm/inch]	Housing dimensions [PN 16 / ANSI 150]							Weight without pump [kg]	Weight with pump [kg]
	L [mm]	A [mm]	B no pump [mm]	B with pump [mm]	C no pump [mm]	C with pump [mm]	H [mm]		
25/1" flanged	150	65	55	165	120	230	195	5.4	6.1
25/1" threaded	150	65	55	165	120	230	195	5.4	6.1
25/1" threaded*	280	65	55	165	120	230	195	5.4	6.1
40/ 1 1/2 threaded	150	65	55	165	120	230	195	5.4	6.1
50/2" a	75	60	70	150	130/235	210/315	225	4.3	5.1
50/2" b	60	60	70	150	130/235	210/315	225	4.3	5.1
80/3"	120	80	90	210	170/270	290/390	260	6.7	7.4
100/4"	150	90	100	220	190/290	310/410	285	8.4	9.2
150/6"	180	120	120	240	240/360	360/460	335	13.0	13.8

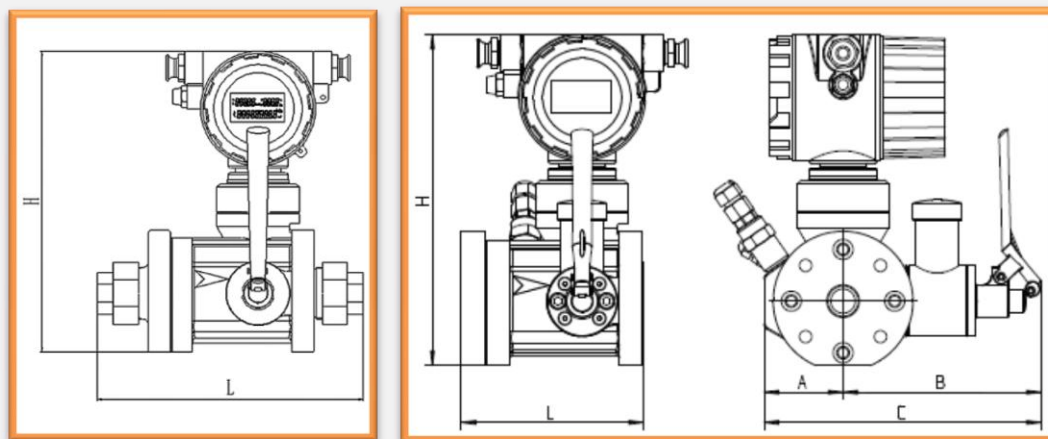

*25/1" threaded , L=280

The pressure loss of the TBQSe Quantometer is minimized through a fluid dynamically optimized inlet diffusor, very low manufacturing tolerances and the high precision, low friction ball bearings.

The optimized flow conditions allow a minimal straight inlet pipe of ≥ 3 DN. If the installation conditions allow or in case of severe flow perturbations acc. to OIML a straight inlet length of ≥ 5 DN is recommended.

Connections

DN [mm/inch]	EN 1092-1 PN 16	ANSI B 16.5 Class 150
25/1" Flanged	4xM12	4xM14
25/1" threaded	Rp1"	Rp1"
40/1 ¹ / ₂ " threaded	Rp1 ¹ / ₂ "	Rp1 ¹ / ₂ "
50/2"	4xM16	4xM16
80/3"	4xM16	4xM16
100/4"	8xM16	8xM16
150/6"	8xM20	8xM20

TBQSe Quantometer housings are manufactured without flanges as a "sandwich" design to be installed between the two inlet and outlet pipe flanges on a standard basis with raised face (RF) flanges according to EN 1092-1 or ANSI B 16.5 for class 150 with a maximum operating pressure of 16 bar/ 2,0MPa. TBQSe DN 25/1" is designed as flange version and threaded version. DN40 is with threaded connection only.

More technical details, especially for commissioning and operation, please refer to the operation manual of the TBQSe turbine meter.

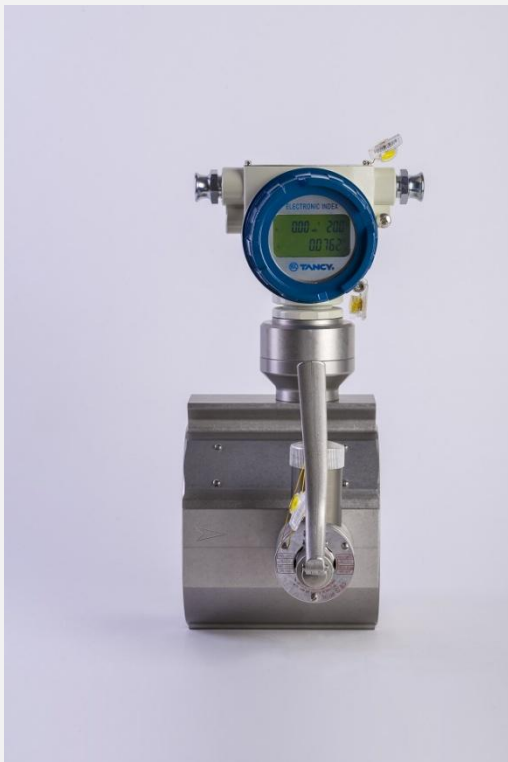



Your contacts:

Tancy Instrument Group Co.,Ltd.
198 Hualian Rd
Cangnan Industrial park, Wenzhou, Zhejiang,
China

Telephone : +86-577-68858028

Fax : +86-577-68858061

Email : info@tancy.com

www.tancy.com